



2 Dibuixa dues coses que tinguin la **e** en el nom:



3 Encercla la lletra **e**:

pèl deu peix elefant
 verd mel peu



4 Repassa i escriu:

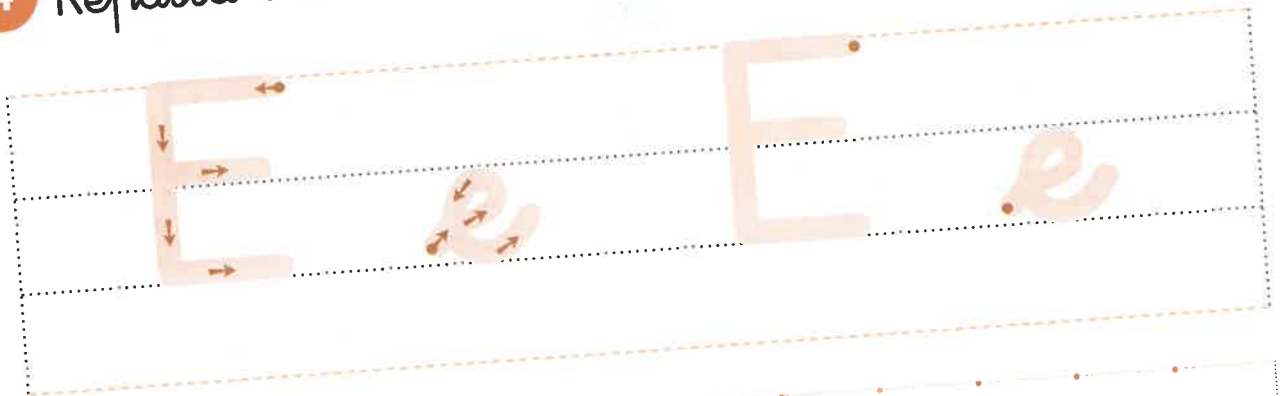

E E E E

e e e e

ei ei ei

ie ie ie

Anàlitzar com s'articula el so: obertura de la boca. Visualitzar la grafia. 1. Dir en veu alta el que representen els dibuixos i notar la diferent obertura de la o. Relacionar les imatges segons el so de la o que tinguin els noms corresponents. Fer una ratlleta per cada so que té el nom de cada dibuix, com en el model. Classificar (l'escriure) els noms on correspongui.

6 sons	4 sons	3 sons

● Classifica:

● Fes una ratlleta per cada so a seta dels dibuixos.



● Relaciona segons com soni la o:



1 Digueu en veu alta què són aquests dibuixos:



 2 Dibuixa dues coses que tinguin la **o** en el nom:



 3 Encercla la lletra **o**:

doŀi llop mona ocell pou gos
ona so nou oca sol no

 4 Repassa i escriu:

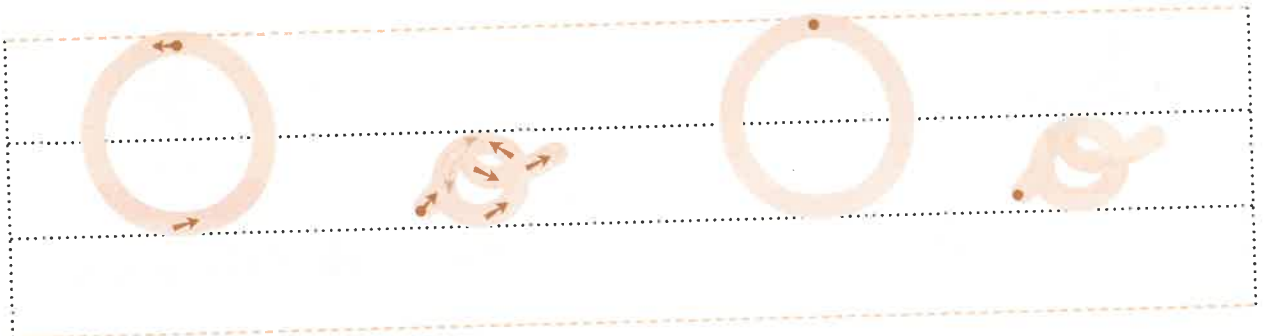

o o o o

o o o o

ou ou ou oi oi oi

AVALUACIÓ

1

1 Relaciona cada dibuix amb una lletra:



e
a
i
u
o



2 Relaciona cada imatge amb la posició de la i:



Al principi: i-
Enmig: -i-
Al final: -i

AVALUACIÓ



3 Fes una ratlleta per cada so que té cada paraula i compta:



--- 3













4 Encercla les lletres **o**, **u**, **a**:

Un tren petitó
que corria, que corria.
Un tren petitó
que corria sense por.



5 Repassa i escriu:







ou ai uau ui ee au

Anallitzar el punt i el mode d'articulació del so. Visualitzar-ne la grafia. 1. Dir en veu alta el que representen els dibuixos i encerclar els que tenen una m en el nom. Fer una ratlleta per cada so que té el nom de cada dibuix, com en el model. Classificar (i escriure) els noms on correspongui.

Al principi: m-	Enmig: -m- -m-	Al final: -m
-----------------	----------------	--------------

● Classifica:

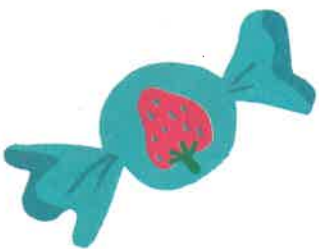
● Feu una ratlleta per cada so a sota dels dibuixos.

1 Encercla els dibuixos que tenen la m en el nom: 



M m

2 Encercla la lletra *m*:

meló camí mimosa caramel
fam muntanya camió mona

3 Repassa i escriu:

M M M M
m m m m
meu mou mua

4 Completa:



à



n



s



o



el



n u



c c



n

Anaïtzar el punt i el mode d'articulació del so. Visualitzar-ne la grafia. 1. Dir en veu alta el que representen els dibuixos i ratllar els que no tenen una p en el nom. Fer una ratlleïta per cada so que té el nom de cada dibuix, com en el model. Escriure paraules que tinguin la lletra p en diferents posicions.

Al principi: p	Enmig: -p	Al final: -p
-------------------	--------------	-----------------

- Fes una ratlleïta per cada so a sota dels dibuïxos.
- Pensa i escriu paraules que tinguin la lletra p:



1 Ratlla els dibuïxos que no tenen la p en el nom:

2 Sessió 2

2 Encercla la lletra *p*:

pal

nap

tapa

gota

fum

pota

paper

quatre

3 Repassa i escriu:

p p p p

pa pe pi po pu

4 Escriu les paraules:



Handwriting practice lines for the word 'pa'.



Handwriting practice lines for the word 'pe'.



Handwriting practice lines for the word 'pi'.



Handwriting practice lines for the word 'po'.



Handwriting practice lines for the word 'pu'.



Handwriting practice lines for the word 'quatre'.

Anàlitzar el punt i el mode d'articulació del so. Visualitzar-ne la grafia. 1. Dir en veu alta el que representen els dibuixos i ratllar els que no tenen una / en el nom. Fer una ratllela per cada so que té el nom de cada dibuix, com en el model. Escriure paraules que tinguin la lletra / en diferents posicions.

Al principi: -l-	Enmig: -l-	Al final: -l

- Fes una ratllela per cada so a sota dels dibuixos.
- Pensa i escriu paraules que tinguin la lletra l:



1  Ratlla els dibuixos que no tenen la l en el nom:

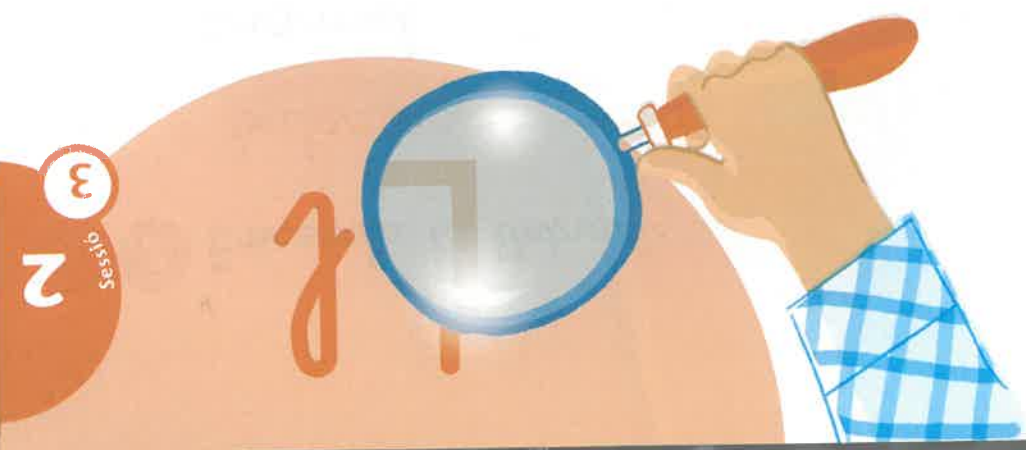

2 Encercla la lletra l:

balena bola aliment fil
caramel lampista lavabo galeta

3 Repassa i escriu:

l l l l
la le li lo lu

4 Escriu les paraules:



Handwriting practice lines for the word 'balena'.

Handwriting practice lines for the word 'bola'.

Handwriting practice lines for the word 'aliment'.



Handwriting practice lines for the word 'caramel'.

Handwriting practice lines for the word 'lampista'.

Handwriting practice lines for the word 'lavabo'.

Anaïtzar el punt i el mode d'articulació del so. Visualitzar-ne la grafia. 1. Dir en veu alta el que representen els dibuixos i encerclar els que tenen una n en el nom. Fer una ratlleta per cada so que té el nom de cada dibuix. Escriure paraules que tinguin la lletra n en diferents posicions.

Al principi: -n	Enmig: -n-	Al final: -n
--------------------	---------------	-----------------

- Fes una ratlleta per cada so a sota dels dibuixos.
- Pensa i escriu paraules que tinguin la lletra n:



1 Ratlla els dibuixos que no tenen la n en el nom:



2 Encercla la lletra *n*:

mona ninot nau mantega
panet cuiner caminet memut

3 Repassa i escriu:

n n n n
na ne ni no nu

4 Escriu les paraules:



Handwriting practice lines for the word 'mona'.



Handwriting practice lines for the word 'ninot'.



Handwriting practice lines for the word 'nau'.

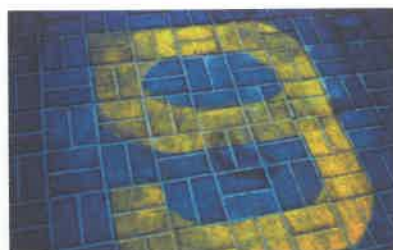

Handwriting practice lines for the word 'mantega'.



Handwriting practice lines for the word 'panet'.



Handwriting practice lines for the word 'cuiner'.

RIMES

2
5
sessió

1 Encercla els dibuixos que rimem amb : 



• Escriu la part que rima:

Handwriting practice lines consisting of a solid top line, a dashed middle line, and a solid bottom line.

2 Encercla els dibuixos que rimem amb : 

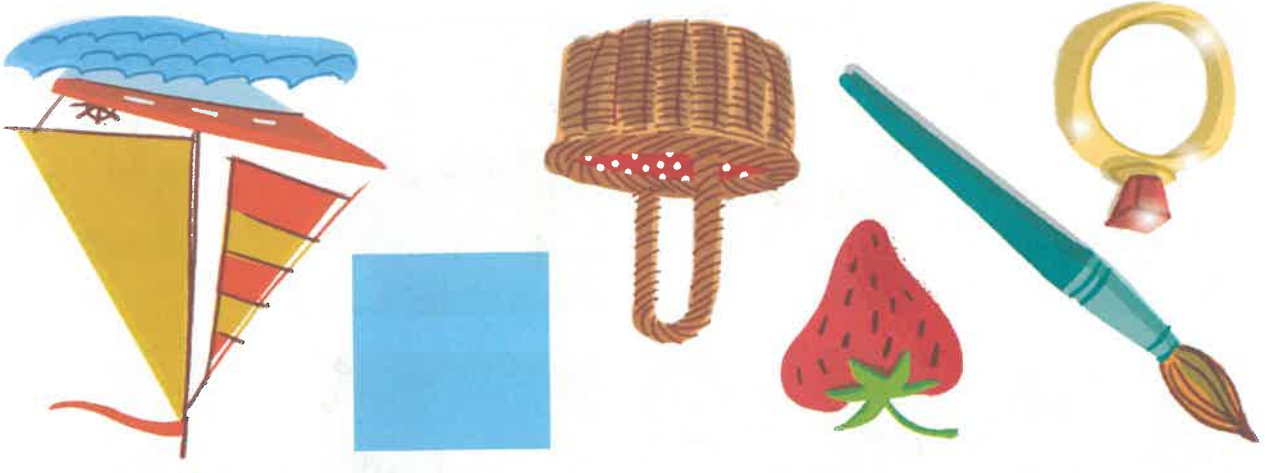

1. Identificar què representen els dibuixos i encerclar els que rimem amb la paraula *raqueta*. Escriure la part que rima.
2. Identificar què representen els dibuixos i encerclar els que rimem amb la paraula *martell*.



3 Aparella els dibuixos que rimen:



Blank handwriting lines for the word 'os'.

os

Blank handwriting lines.

Blank handwriting lines.



4 Pinta segons amb què rimen:



7



- 3. Identificar què representen els dibuixos i aparellar els que rimen. Escriure la part que rima.
- 4. Identificar què representen els dibuixos i pintar de color vermell els requadres dels que rimen amb bata i de color verd els que rimen amb set.

AVALUACIÓ

1 Relaciona cada dibuix amb una lletra:

2



m

n

l

r

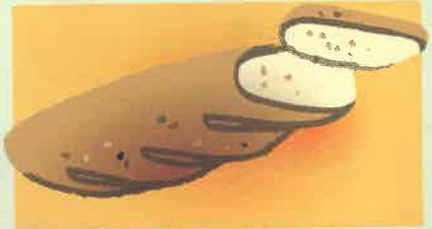

2 Fes una ratlleta per cada so que té cada paraula:



AVALUACIÓ



3 Pensa i escriu dues paraules de cada:

Al principi: m-	Enmig: -r-	Al final: -n



4 Encercla els dibuixos que rimen amb :



estel



- Ara, escriu les paraules a sota dels dibuixos i subratlla la part que rima.

Anàlitzar el punt i el mode d'articulació del so. Visualitzar-ne la grafia. 1. Dir en veu alta el que representa cada dibuix i encercar els que tenen la lletra t en el nom. Classificar els noms segons la posició de la t. 2. Identificar la lletra t en les paraules escrites i encercar-la. 3. Reproduir la grafia. Fixar-se com s'uneix cada lletra amb la següent.

ta te ti to tu

3 Repassa i escriu:



llibreta guitarra telèfon ratolí tobogan
 tornada bigoti gelat sabata tetera

2 Encercla la lletra t:



Al principi: t-	Enmig: -t-	Al final: -t
-----------------	------------	--------------

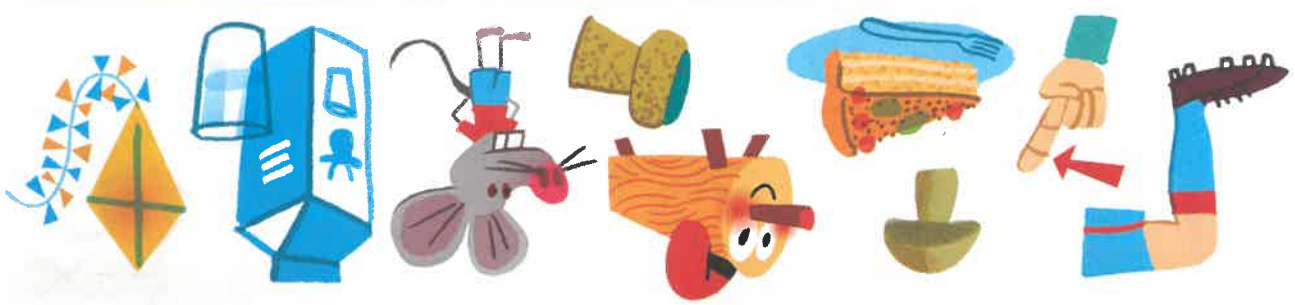

1 Encercla els dibuixos que tenen la t en el nom i classifica les paraules:

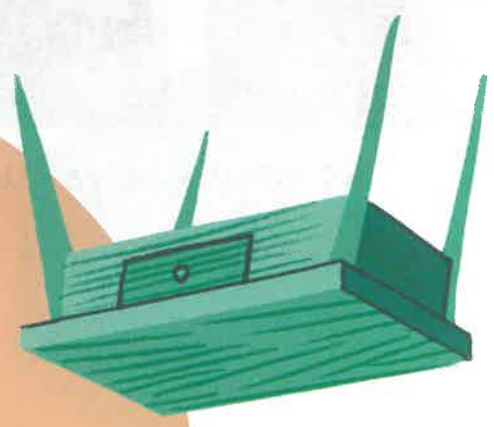

T t



4 Fes una ratlleta per cada so i escriu la paraula que queda si traiem el primer so:



leta









5 Afegeix el so indicat i dibuixa:

- Si afegeixes una **t** a **apa** dirà...
- Si afegeixes una **n** a **ata** dirà...
- Si afegeixes una **p** a **ota** dirà...



DICTAT ▶ 66

Anaïtzar el punt i el mode d'articulació del so. Visualitzar-ne la grafia. 1. Dir en veu alta el que representa cada dibuix i encerclar els que tenen la lletra d en el nom. Classificar els noms segons la posició de la d. 2. Identificar la lletra d en les paraules escrites i encerclar-la. 3. Reproduir la grafia fent atenció com s'uneix cada lletra amb la següent.

da de di de du

3 Repassa i escriu:

bandera calendari dormitori davantal
dimecres verdura diadema didal

2 Encercla la lletra d:

Al principi: d-	Enmig: -d-
-----------------	------------



1 Encercla els dibuixos que tenen la d en el nom i classifica les paraules:

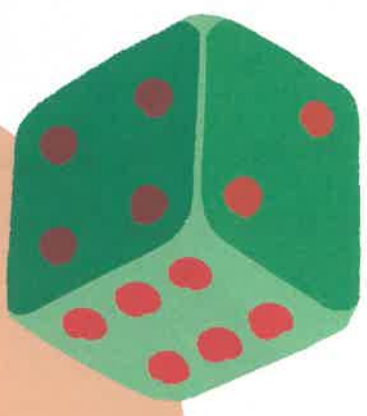

D d

2 3

5



4 Fes una ratlleta per cada so i escriu la paraula que queda si traiem el primer so:



ona



5 Afegeix el so indicat i dibuixa:

- Si afegeixes una **p** a **ila** dirà...
- Si afegeixes una **d** a **ent** dirà...
- Si afegeixes una **d** a **it** dirà...



DICTAT ▶ 66

MÚSICA

L'HARMÒNICA

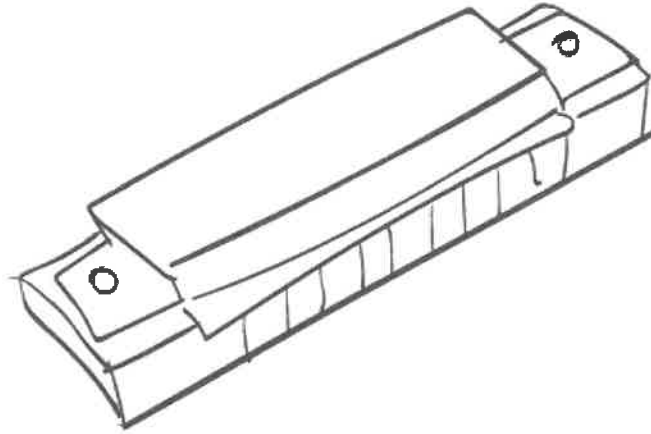

ÉS UN INSTRUMENT DE LA FAMÍLIA DE -----

TÉ ----- FORATS

POT FER ----- NOTES

PER TOCAR-LA BÉ ELS DIBUIXOS HAN D'ESTAR -----

Si has acabat, la pots pintar!

Practica la clau de sol

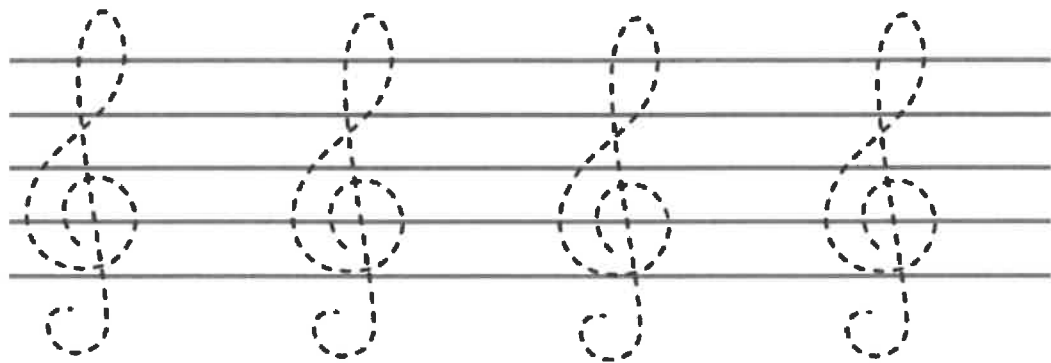
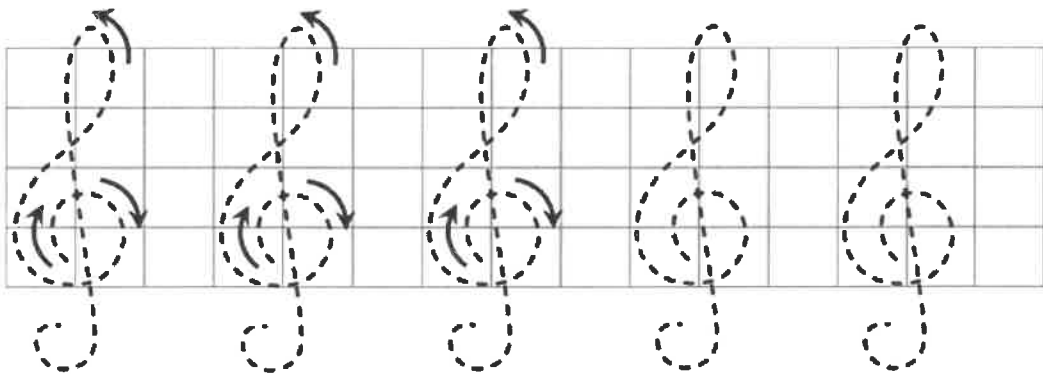
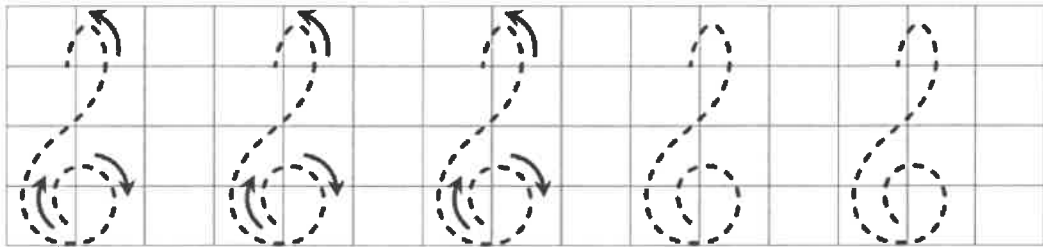
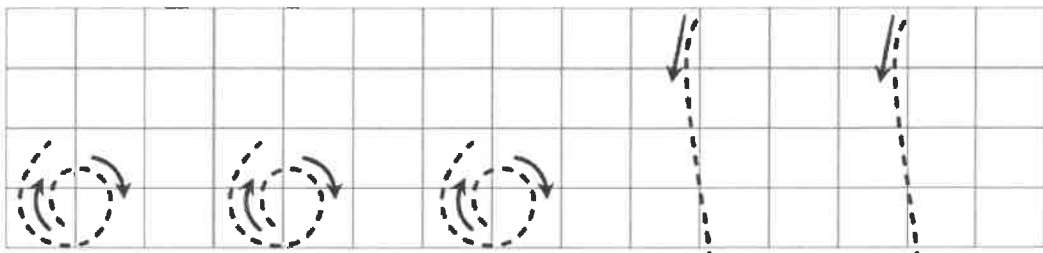

Ara tu sol!

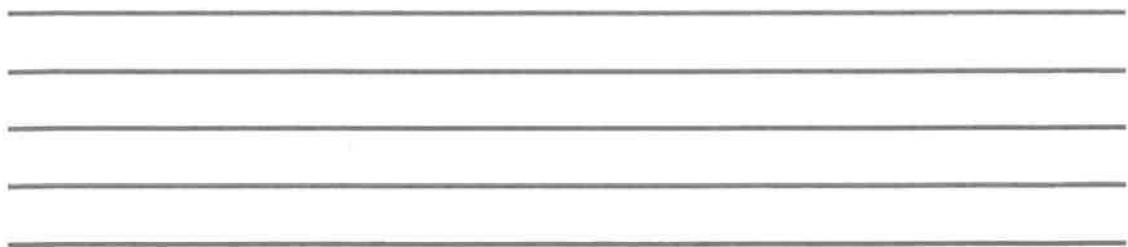

Practico competències

1. Acoloreix cada peça com a la mostra.

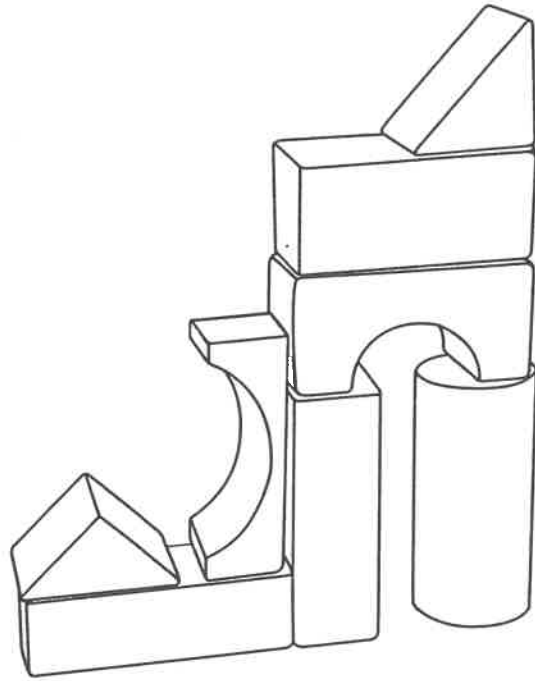
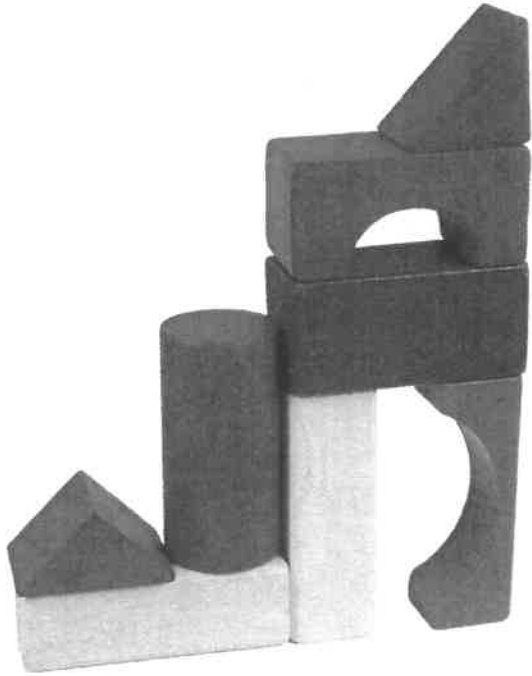

2. Fixa-t'hi i enganxa el nom de cada nen o nena.

- En Pep és tan alt com la Dolors.
- En Bru és el més alt.
- La Rosa és més alta que la Dolors.



1. Suma i resta.

$$\begin{array}{r} 8 \\ + 0 \\ \hline \end{array}$$

.....

$$\begin{array}{r} 2 \\ + 6 \\ \hline \end{array}$$

.....

$$\begin{array}{r} 5 \\ + 1 \\ \hline \end{array}$$

.....

$$\begin{array}{r} 5 \\ - 3 \\ \hline \end{array}$$

.....

$$\begin{array}{r} 7 \\ - 7 \\ \hline \end{array}$$

.....

$$\begin{array}{r} 9 \\ - 2 \\ \hline \end{array}$$

.....

2. Encercla en cada parell.

El nombre més gran

15 7

28 20

El nombre més petit

16 9

27 13

3. Dibuixa i resol.



- En un plat hi ha 5 pomes i 3 peres. Quantes fruites hi ha?

..... =

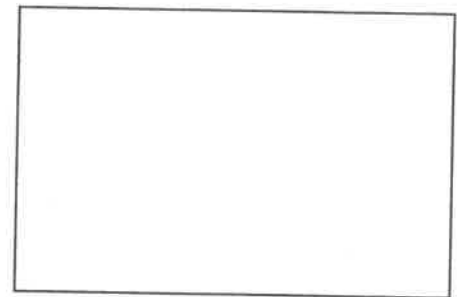

Hi ha fruites.

- En Pep té 10 galetes. Si en regala 4 a en Jan, quantes li'n queden?

..... =

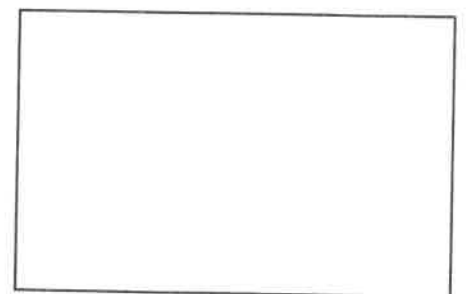

Li queden galetes.

• 12. Fixa't en el dibuix i resol.





Situacions de suma i resta. Elegir l'operació i resoldre.

- Hi ha 4 . Si arriben 3  més, quants n'hi haurà?

$$\dots \square \dots = \dots$$

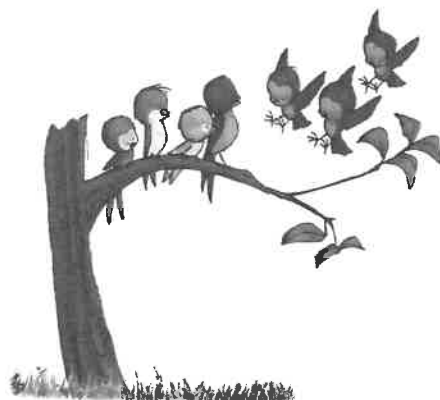
Hi haurà  \dots .





- Hi ha 9 . Si se'n van 4 , quantes en quedaran?

$$\dots \square \dots = \dots$$

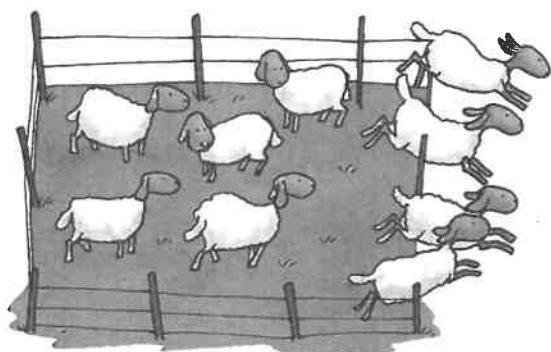
Quedaran  \dots .



- Hi havia 8  i se'n van 3 . Quants en queden?

$$\dots \square \dots = \dots$$

Queden  \dots .



Càlcul mental...

Restar 1 i 2 de nombres fins al 9. Jo dic 4 - 2 i tu escrius 2: 4 - 2, 6 - 1, 5 - 2, 3 - 1, 8 - 2, 9 - 1.

2

Dibuixa o ratlla i resol.

Resolució gràfica de situacions de suma o resta.

- Si compro 3 cotxes més, quants en tindrè?

$$5 + 3 = \dots$$

Tindrè cotxes.



- Si agafó 4 flors, quantes en queden?

$$\dots \square \dots = \dots$$

Queden flors.



- Tinc 3 peixos vermells. Si en compro 2 de blaus, quants peixos tindrè?

$$\dots \square \dots = \dots$$

Tindrè peixos.



- Si apago 3 espelmes, quantes en quedaran d'enceses?

$$\dots \square \dots = \dots$$

Quedaran espelmes enceses.

